



A Tsurumi Pump Company

# PRODUCT DATA SHEET

APG HIGH HEAD DRAINAGE

ZEN-APG750/2/G50HA0FTEX | 807403

## PRODUCT DETAILS

Zenit's APG Grey Series electric, submersible pumps feature completely redesigned hydraulics with high-head, open multi-channel impellers and high-efficiency motors, guaranteeing high performance and low costs.

## APPLICATIONS

Ideal solution for pumping clean water, rainwater and seepage water containing small particles in suspension, suitable for heavy-duty professional use. Also suitable for secondary treated wastewater, greywater recycling, and non-potable reuse systems.

## FEATURES

- Cast-iron body, impeller and flange EN-GJL250
- AISI 431 motor shaft
- 2-pole, 3-phase motor
- Class H insulation [180°C]
- IP68 protection
- Thermal protections integrated into the stator
- Moisture detection probe fitted to mechanical seal oil chamber
- Two-component epoxy painting 150µm
- Two silicon carbide [SiC] mechanical seals inside the oil chamber
- 10mm free passage
- Cable length 10m



IMAGE INDICATIVE ONLY

## TECHNICAL DATA

<b>RATED POWER P1 / P2</b>	6.3kW / 5.5kW
<b>MAX. FLOW [Q]</b>	10.3 L/sec
<b>MAX. HEAD [M]</b>	44.7 m
<b>MOTOR INSULATION</b>	H Class
<b>PROTECTION CLASS</b>	IP68
<b>MOTOR PROTECTION</b>	Thermal protection and moisture detection
<b>MOTOR DUTY</b>	Continuous Use S1
<b>MAX. LIQUID TEMPERATURE</b>	40°C
<b>MECHANICAL SEAL</b>	Dual Silicon Carbide
<b>MAX. DENSITY AND PH</b>	1.100 kg/m <sup>3</sup>   pH 6 – 14

<b>RATED VOLTAGE</b>	400V 3ph 50Hz
<b>MOTOR POLES</b>	2-pole
<b>CURRENT</b>	Rated FLC 10.8A DOL current 77.8A
<b>POWER CABLE TYPE</b>	10m H07RN-F Cable
<b>MAX. HYDRAULIC EFFICIENCY</b>	49.9%
<b>FREE PASSAGE</b>	10 mm
<b>IMPELLER TYPE</b>	High-head impeller
<b>SUCTION</b>	
<b>OUTLET</b>	DN50 – G2"
<b>WEIGHT (KG)</b>	60.3 kg (pump only)

## CURVE

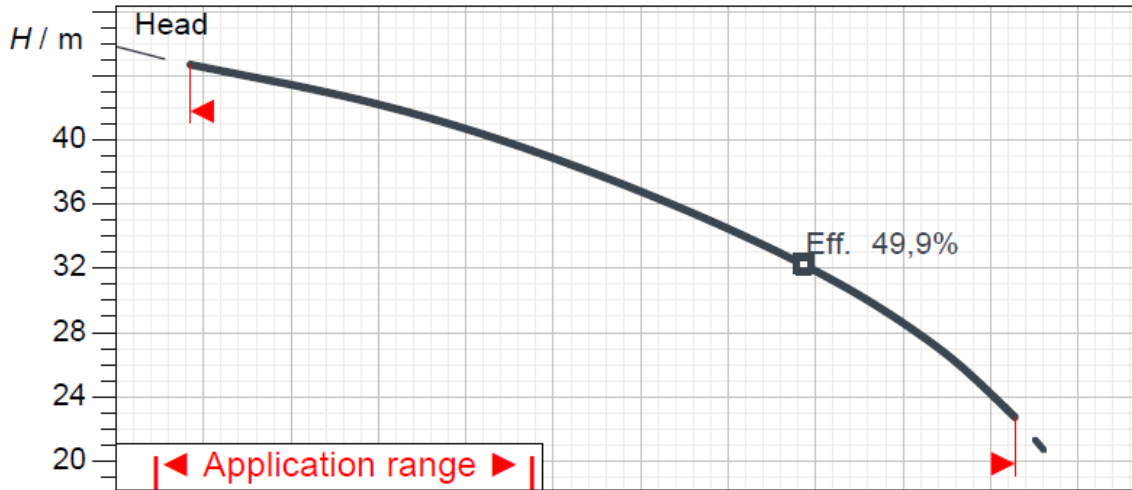

## DIMENSIONS

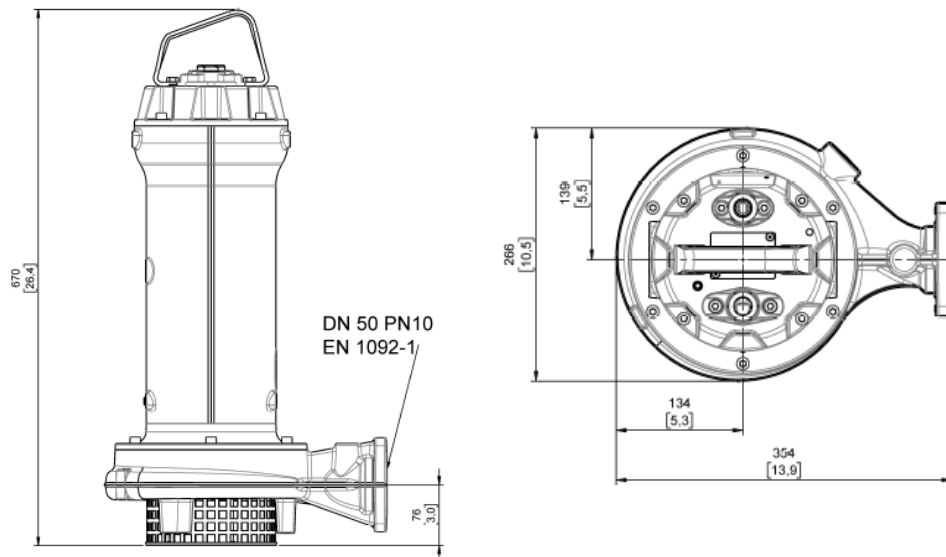

## WARRANTY / CERTIFICATIONS

